

DWG. No./Part No.:					CODE:	DESCRIPTION:	MATERIAL:	FINISH:	
C-118					S	HOSE COUPLER, CGA-030	.5625 HEX BRASS	BRITE-DIP	
REV	ECN	DATE	CHKD	APPVD	TOLERANCES UNLESS SPECIFIED:		INTERPRET GEOMETRIC TOLERANCING PER: ANSI Y14.5		
A	REDRAWN	08/01/06	GDG	MRE	125 FINISH ALL OVER REMOVE ALL BURRS BREAK ALL CORNERS .015/.005 DECIMAL .XX +/- .015 .XXX +/- .005 ANGULAR +/- 1 CONCENTRICITY .007 TIR		DO NOT SCALE		
B	10-0083	04/09/10	GDG	PSM	<b>NOTICE:</b> THE DATA IN THIS DOCUMENT INCORPORATES PROPRIETARY INFORMATION AND RIGHTS OF SUPERIOR PRODUCTS, INC. CONFIDENCE AND AGREES THAT IT SHALL NOT BE DUPLICATED IN WHOLE OR IN PART, NOR DISCLOSED TO OTHERS WITHOUT THE WRITTEN CONSENT OF SUPERIOR PRODUCTS, INC.				

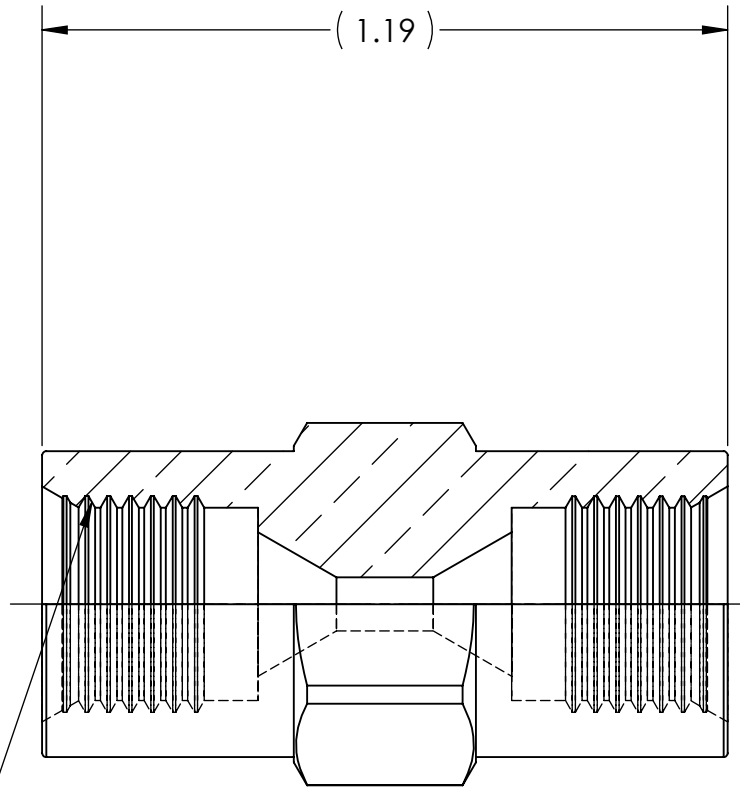
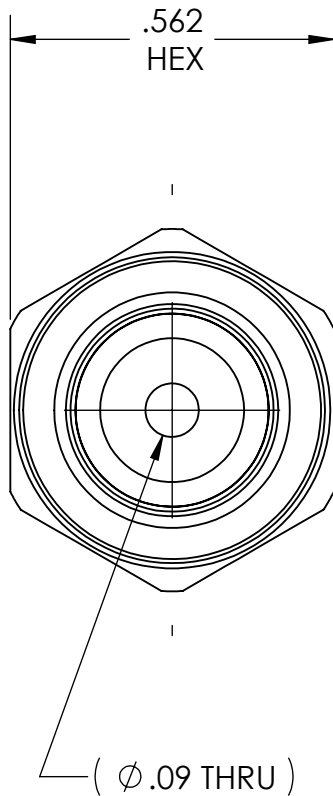

3/8-24 RH  
CGA - E1  
CONN - 030  
TYP