

DWG. No./Part No.: PTH-3300					CODE: S	DESCRIPTION: RIGID PIGTAIL, 1-LOOP, CGA-300	MATERIAL:	FINISH: TO BE FREE FROM OIL AND DIRT	
REV	ECN	DATE	CHKD	APPVD	<u>TOLERANCES UNLESS SPECIFIED:</u> 125 FINISH ALL OVER REMOVE ALL BURRS BREAK ALL CORNERS .015/.005 DECIMAL .XX +/- .015 .XXX +/- .005 ANGULAR +/- 1 CONCENTRICITY .007 TIR	<u>NOTICE:</u> THE DATA IN THIS DOCUMENT INCORPORATES PROPRIETARY INFORMATION AND RIGHTS OF SUPERIOR PRODUCTS, INC. CONFIDENCE AND AGREES THAT IT SHALL NOT BE DUPLICATED IN WHOLE OR IN PART, NOR DISCLOSED TO OTHERS WITHOUT THE WRITTEN CONSENT OF SUPERIOR PRODUCTS, INC.	INTERPRET GEOMETRIC TOLERANCING PER: ANSI Y14.5		
A	021803A	01/28/09	GDG	RJJ				DO NOT SCALE	
B	09-0059	02/25/09	GDG	PSM					

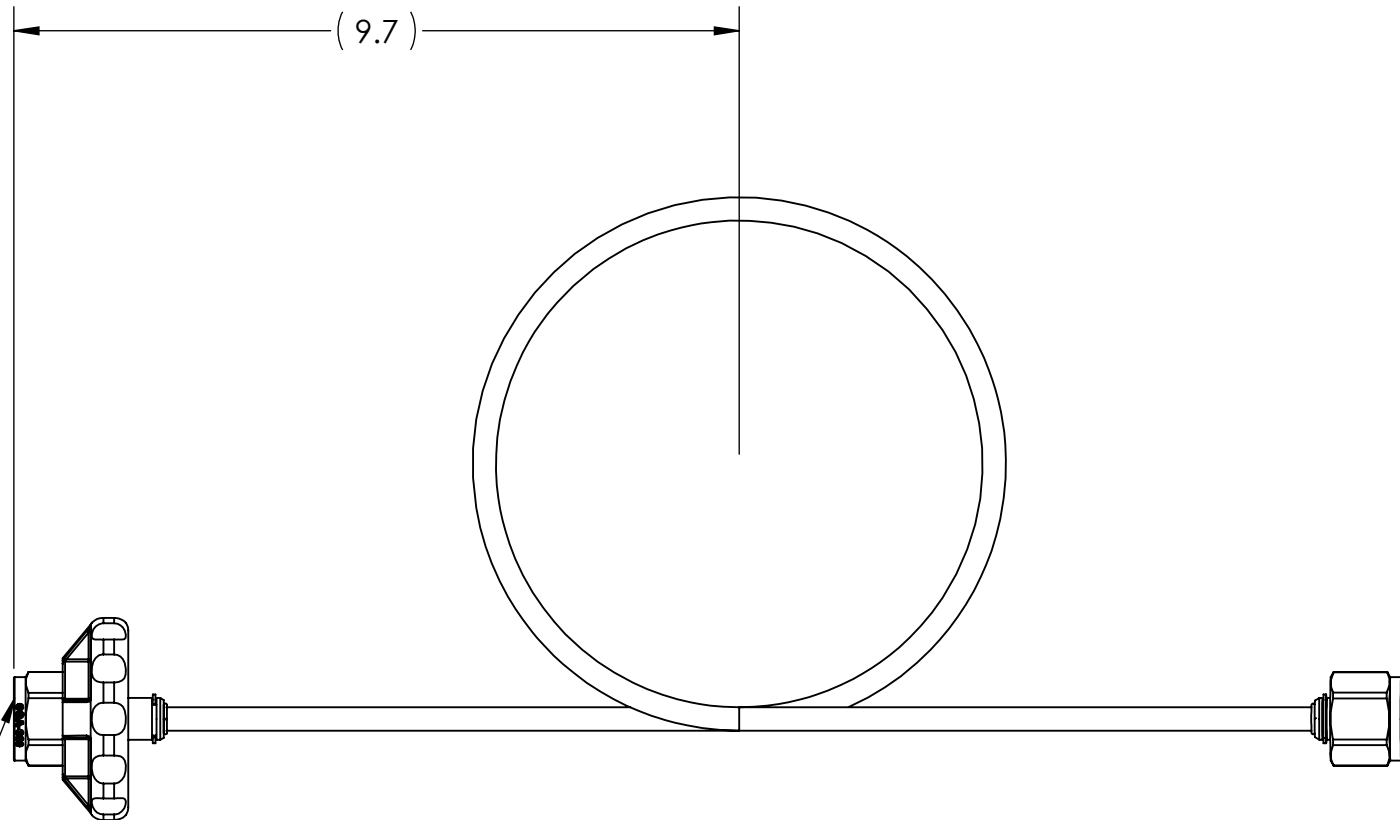

.830-14 RH NGO
 CGA - V1
 CONN - 300
 TYP